

SURF CITY

AN INTERNET CAFE

A TRUE STORY



Written by Robert Breedlove
surfcityfilms@gmail.com | (407) 619-6478

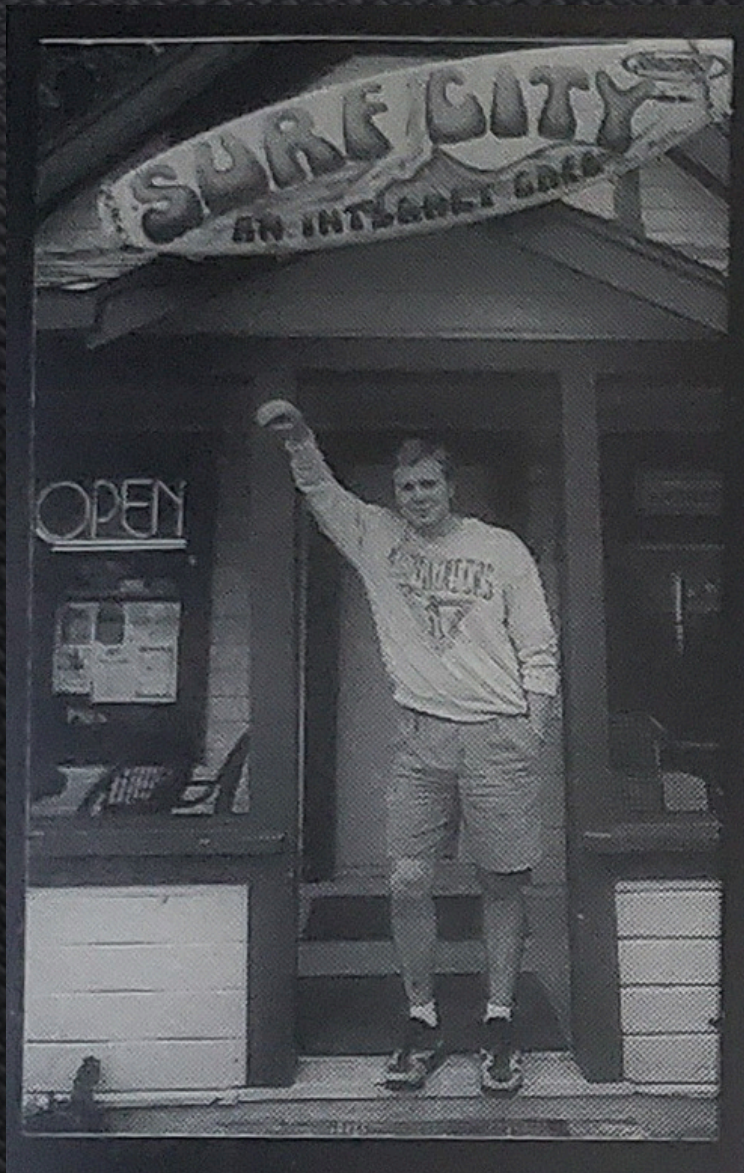

LOG LINE

A MILITARY VET OPENS ALASKA'S FIRST MMO-CENTRIC INTERNET CAFE, BUT WHEN GAMING GIANTS WIPE OUT HIS EVERQUEST REVENUE, HE PIVOTS RUTHLESSLY TO SURVIVE.

WRITER BIO

ROBERT BREEDLOVE IS A U.S. AIR FORCE VETERAN AND FORMER DOD EXPLOSIVES INSPECTOR, WHO IN 1996, FOUNDED SURF CITY, ONE OF THE NATION'S FIRST HARD-WIRED INTERNET GAMING CAFES

THIS AUTOBIOGRAPHICAL STORY DRAWS FROM HIS REAL DOUBLE LIFE, BUILDING A DIGITAL FRONTIER BY DAY WHILE SERVING AS AN EXPLOSIVES INSPECTOR BY NIGHT.

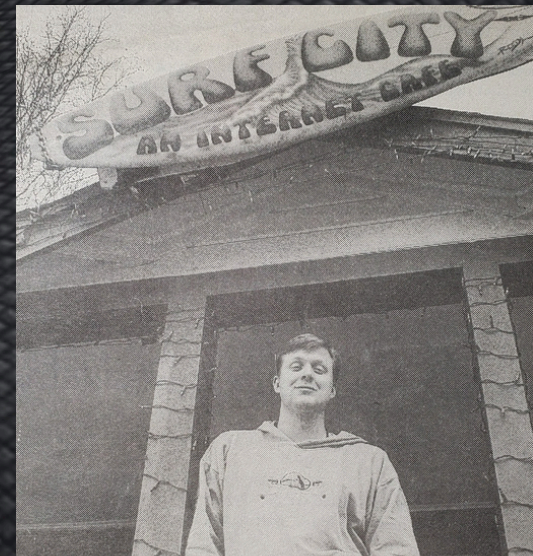



The deli at Surf City, next to "the closet to nowhere."

Surf City
located at 415 L Street 279-7877
Alaska's only hard wired internet café
www.surfcafe.com



9 networked Macs and PCs
400K digital wireless net connection
Open until 10 pm every night

All Winter
Net time after 7:00 pm (weekdays) is just 8¢ a min, and Game time is just 5¢ a min anytime!! (Wow!!!)

Join us for the official
Myth II: Soulblighter release
tournament...free game time,
multiplayer fun, and prizes!!!
Tournaments January 22-24
Stop by or call for more information & sign up



THE WORLD / SETTING

ANCHORAGE, ALASKA, 1996
THRU 2002. SNOW-COVERED
STREETS, ENDLESS WINTERS
AND A TINY GREEN HOUSE
TRANSFORMED INTO A
GLOWING HUB OF ACCESS.

TEN BLAZING PCS, ESPRESSO
STEAM, AND THE HUM OF
BEIGE TOWERS.

WHERE THE LAST FRONTIER
COLLIDED WITH THE DIGITAL
FRONTIER.

TONE / STYLE

A 90'S DRAMEDY WITH HEART
- THE SOCIAL NETWORK
MEETS EMPIRE RECORDS IN A
SNOWBOUND ALASKAN
TUDOR.

NOSTALGIC CRT GLOW,
OVERCLOCKED VIDEO-CARD
HUM, PIXELATED RAIDS, AND
REAL HUMAN STAKES. FUNNY,
RAW, AND
UNAPOLOGETICALLY GEEKY.

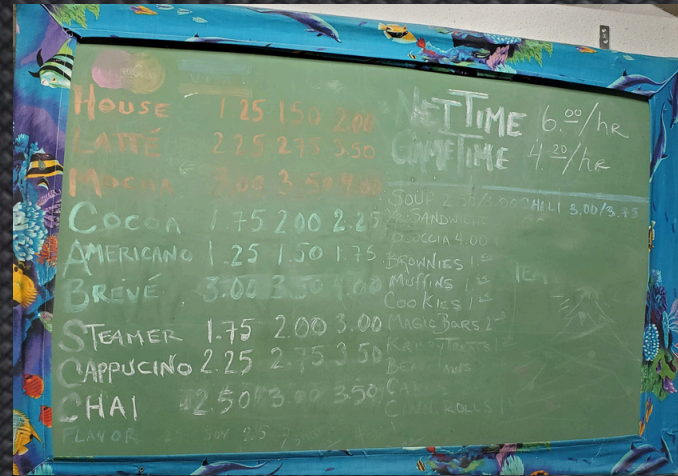

269884095	Feb-25-00	Mar-01-00 19:12:29	\$27.00	Everquest Mith Marr - Erudite Heart Amulet	tryan012 (2)(*)
269885422	Feb-25-00	Mar-01-00 19:13:50	\$57.00	Everquest Mith Marr - Robe of the Oracle	tryan012 (2)(*)
269886837	Feb-25-00	Mar-01-00 19:15:04	\$61.00	Everquest Mith Marr - Dwarven Workboots	cpzen (2)(*)
269888000	Feb-25-00	Mar-01-00 19:16:14	\$20.50	Everquest Mith Marr - Silversilk Leggings	rk1066@aol.com (188) ☆ (*)
269889524	Feb-25-00	Mar-01-00 19:17:33	\$25.00	Everquest Mith Marr - Black Pearl Choker	cnarvas (2)(*)
269890398	Feb-25-00	Mar-01-00 19:18:25	\$37.95	Everquest Mith Marr - Platinum Star Ruby Veil	maveric1@mindspring.com (8) (*)
269891641	Feb-25-00	Mar-01-00 19:19:37	\$37.25	Everquest Mith Marr - Darkmail Gauntlets	gpcady (3)(*)
269893054	Feb-25-00	Mar-01-00 19:21:03	\$96.00	Everquest Mith Marr - Runed Falchion	tryan012 (2)(*)
269894052	Feb-25-00	Mar-01-00 19:22:05	\$111.50	Everquest Mith Marr - BOX OF ABU-KAR!	maveric1@mindspring.com (8) (*)
269894959	Feb-25-00	Mar-01-00 19:22:57	\$81.00	Everquest Mith Marr - 2000 platinum!	rk1066@aol.com (188) ☆ (*)
269895733	Feb-25-00	Mar-01-00 19:23:40	\$41.00	Everquest Mith Marr - 1000 platinum!	msjl@advnet.net (2)(*)
269898348	Feb-25-00	Mar-01-00 19:26:27	\$143.50	Everquest Tunare - FISHBONE EARRING!	nack91 (3)(*)
269899540	Feb-25-00	Mar-01-00 19:27:42	\$46.00	Everquest Tunare - FLAYED TURMOILSKIN BELT!	naiahannah (22) ☆ (*)
269903767	Feb-25-00	Mar-01-00 19:31:59	\$313.00	Everquest Tunare - HOODED BLACK CLOAK!!!!!!	eqshopper1 (1)(*)
	Feb-25-00	Mar-01-00		Everquest Tunare -	

.../eBayISAPI.dll?MfcISAPICommand=ViewListedItems&user=ctzctzax&include=0&since 03/29/2000

SYNOPSIS

ROB, A MILITARY VET, OPENS SURF CITY, ALASKA'S FIRST HARD-WIRED GAMING CAFE, TRANSFORMING A QUIET COFFEE SHOP INTO A BOOMING MMO HUB.

AS EVERQUEST EXPLODES, VIRTUAL ITEM TRADING FUELS AN UNDERGROUND ECONOMY.

BUT WHEN CORPORATE CEASE-AND-DESISTS THREATEN EVERYTHING, ROB FACES A CHOICE: SELL OUT OR FIGHT TO PROTECT THE WORLD HE BUILT AND THE FOUND FAMILY HE FORGED.

KEY CHARACTERS

ROB: RELENTLESS DREAMER AND MILITARY VET TURNED CAFE OWNER - EQUAL PARTS GRIT AND GEEK.

VANDRA: FIERCE RAID LEADER AND BARISTA; LOYAL, SHARP, AND AMBITIOUS.

BEN: A METICULOUS, SOFT-SPOKEN TECH SAVANT WITH MONK-LEVEL FOCUS

DAVE: SHARP-WITTED CODER WITH A CHAOTIC STREAK - CAN SPIN UP A SERVER FROM SCRATCH WHILE TALKING TRASH IN GUILD CHAT

CHADWICK: A SLICK DOT-COM OPPORTUNIST - THE FUTURE CRASHING THROUGH THE FRONT DOOR.





COMPARABLE FILMS

THE SOCIAL NETWORK

Innovation, ambition, and betrayal inside a rising tech ecosystem.

EMPIRE RECORDS

Found-family chaos inside a niche, culture-driven business



HALT AND CATCH FIRE

The emotional grind and frontier spirit of '90s tech pioneers.

THE FOUNDER

Ruthless pivots, survival instincts, and the cost of chasing a dream.

THEMES & WHY NOW

NOSTALGIA FOR 90'S GAMING CULTURE MEETS MODERN QUESTIONS ABOUT DIGITAL ECONOMIES, CORPORATE OVERREACH, AND BUILDING COMMUNITY IN ISOLATION.

IN A WORLD OF NFTS, CRYPTO, AND VIRTUAL WORLDS, SURF CITY ASKS A SIMPLE QUESTION: WHAT HAPPENS WHEN THE FUTURE ARRIVES TOO FAST?

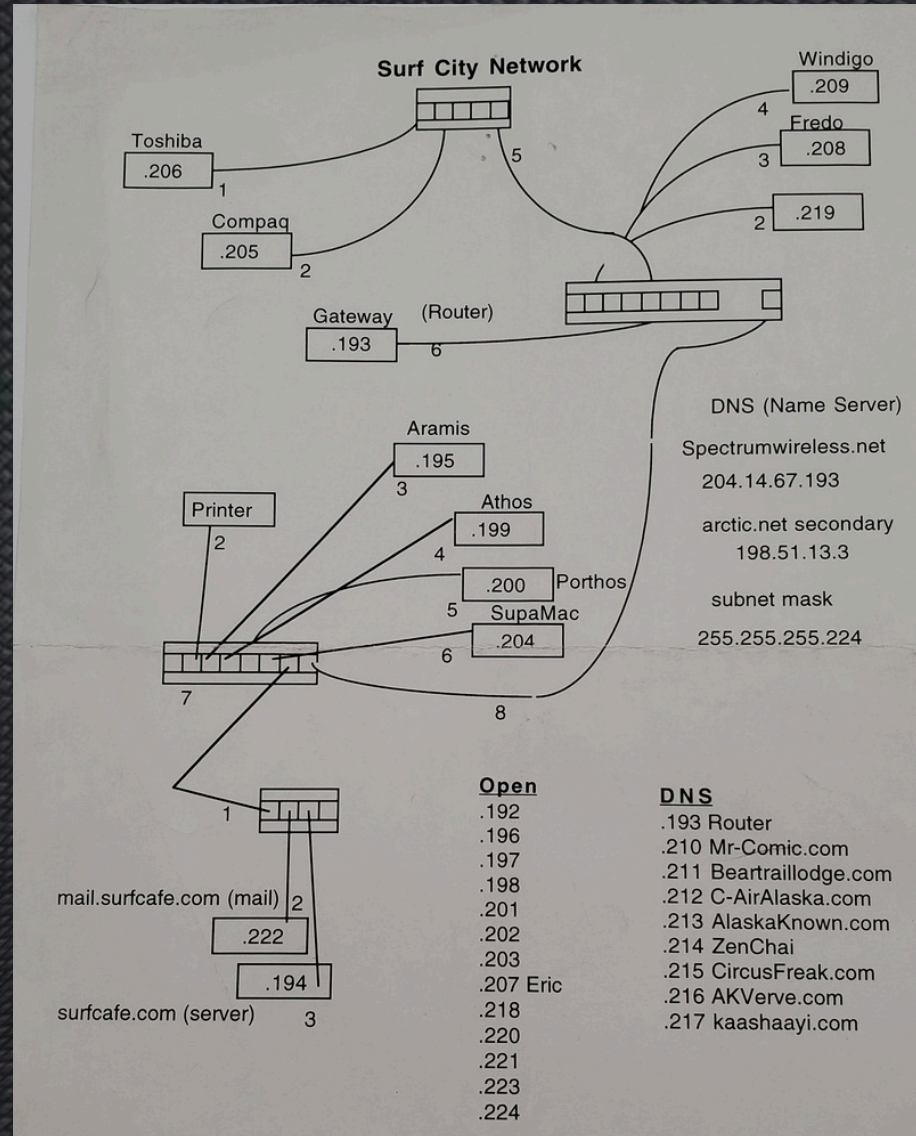

Surf City Inc.
 (An Alaskan Corporation)

Corporate Office:
 415 L Street
 Anchorage, AK 99501
 907-279-7877

Principal contact is Robert Bredrove - President
 May 1996

This Business Plan has been prepared by the management team of Surf City Inc., and is being furnished to select individuals for the sole purpose of providing general information only. This Business Plan does not constitute an offer of securities, and should not be used as a basis for investment decisions. Readers are to view the information contained herein as confidential and not to use any of these materials without the written permission of the Company.

MAGIC
The Gathering™

On-Line Tournament!!
 Friday the 13th

at
Surf City
FREE (no sign-up early)

*Game play will be conducted over the internet, so leave those cards at home.
 Pre-register before 3pm friday. Be at Surf City by 5:30pm. Deck construction at 6pm. Tournament will begin at 7pm.*

Surf City, an internet cafe
415 L Street (across from Simon's & Seaford's)
To register or for more info call (907)279-7877



Magic: The Gathering is a registered trademark of Wizards of the Coast Inc.

PROOF OF LIFE / TRUE STORY

**BASED ON REAL EVENTS —
 INSPIRED BY SURF CITY, ONE
 OF FIRST HARD-WIRED
 INTERNET CAFES IN THE
 NATION (1996).**



**DOCUMENTED IN A 1999 NEW
 YORK TIMES FEATURE AND
 SUPPORTED BY MANY
 SURVIVING ARTIFACTS FROM
 THE ORIGINAL BUILD.**



CURRENT MOMENTUM



TEAM / NEXT STEPS

WRITER / PRODUCER:
**ROBERT BREEDLOVE (DEBUT
FEATURE):** BUILDING A
PROOF-OF-CONCEPT SHORT
(THE PIXEL CARTEL) TO
SHOWCASE TONE, WORLD,
AND CHARACTER.

SEEKING: DIRECTOR,
PRODUCERS, REPS, AND
CREATIVE COLLABORATORS
INTERESTED IN DEVELOPING
THE SHORT AND EXPLORING
FEATURE-LEVEL
PARTNERSHIP
OPPORTUNITIES.

OPEN TO: FEEDBACK,
STRATEGIC PARTNERSHIPS,
AND CONVERSATIONS THAT
HELP BRING SURF CITY TO
THE SCREEN.

Robert Breedlove in front of his cafe



PHOTO BY FOR HALL/INFER / PHOTOGRAPHY GROUP NEWS

NATURE IN A BOX



DOG JOG

Friends of Pets, a volunteer organization dedicated to finding homes for abandoned cats and dogs, holds its second annual Dog Jog 5-K and 1-mile benefit run at 11 a.m. Saturday, Aug. 3, at Kincaid Park. Registration takes place at 9 a.m. that day. Cost is \$15 for adults, \$3 for youth. Call 562-2535.

FRESH



AIR

Sittin', slurpin' and surfin' the Net

By Cheryl

Kirk

*oday's Special — Latte plus
1 hour of Internet Surfing.*

There's only one place in Anchorage you can find that special on the menu: Surf City, a downtown coffeehouse turned cyber-cafe.

With powerful computers, a network server, a color scanner and an espresso machine, Surf City is a place to get wired on both caffeine and technology. Though other, more humble efforts have been made at mixing coffee and computers, the advent of Surf City firmly plugs Anchorage into the fast-growing, international cyber-cafe culture.

At last count, some 300 cyber-cafes were in existence in the United States, with another 400 scattered across the globe. Cafes like CyberJava in Venice, Calif., see 70 percent of their income from the on-line side, with the rest in coffee and food sales. The Edge, a new entrant in the heavily populated cyber-cafe market in England, saw 19,000 people walk through its doors in a single day during a recent grand opening, according to reports in Internet magazine, a British publication.

The idea is simple. People have been coming to neighborhood coffeehouses for years to share good drink, good food and good conversation. Add a few computers to that mix, connect them to the global Internet, offer the patrons the ability to get electronic mail, play electronic video games with each other or chat in real time with someone a world away, and you have the dawning of a

SPORTS
HIKES
ACTIVITIES